

BALDOR® • RELIANCE 

Product Information Packet

EM4468T

60HP,890RPM,3PH,60HZ,405T,TEFC,F1

Part Detail							
Revision:	B	Status:	PRD/A	Change #:		Proprietary:	No
Type:	AC	Elec. Spec:	A40WG0790	CD Diagram:	416820-002	Mfg Plant:	
Mech. Spec:		Layout:	617429-001	Poles:	08	Created Date:	04-02-2015
Base:		Eff. Date:	04-06-2018	Leads:	3#4,6#6		

Specs			
Catalog Number:	EM4468T	Feedback Device:	NO FEEDBACK
Enclosure:	TEFC	Heater Indicator:	No Heater
Frame:	405T	Insulation Class:	F
Frame Material:	Iron	Inverter Code:	Inverter Ready
Output @ Frequency:	60.000 HP @ 60 HZ	IP Rating:	NONE
Synchronous Speed @ Frequency:	900 RPM @ 60 HZ	KVA Code:	F
Voltage @ Frequency:	230.0 V @ 60 HZ	Motor Lead Quantity/Wire Size:	3 @ 4 AWG
	460.0 V @ 60 HZ	Motor Type:	A40060M
XP Class and Group:	None	Mounting Arrangement:	F1
XP Division:	Not Applicable	Power Factor:	79
Agency Approvals:	CCSA US	Product Family:	General Industrial
	CSA EEV	Pulley End Bearing Type:	Ball
Auxillary Box:	No Auxillary Box	Pulley Face Code:	Standard
Base Indicator:	Rigid	Shaft Ground Indicator:	No Shaft Grounding
Bearing Grease Type:	Polyrex EM (-20F +300F)	Shaft Rotation:	Reversible
Current @ Voltage:	152.000 A @ 230.0 V	Shaft Slinger Indicator:	No Slinger
	76.000 A @ 460.0 V	Speed Code:	Single Speed
Design Code:	B	Motor Standards:	NEMA

Drip Cover:	No Drip Cover	Starting Method:	Direct on line
Duty Rating:	CONT	Thermal Device - Winding:	None

Nameplate NP2496L

MOBIL POLYREX EM

Nameplate NP2349L										
SPEC NO.	A40-6568-0790			CAT.NO.	EM4468T			FRAME	405T	
HP	60	VOLTS	230/460		PHASE	3	DESIGN	B	TYPE	P
RPM	890	AMPS	152/76		HZ	60	AMB	40	SF	1.15
DRIVE END BEARING	80BC03J30X		DUTY	CONT		INSUL.CLASS	F			
OPP D.E. BEARING	80BC03J30X		ENCL	TEFC		CODE	F			
SER.NO.				POWER FACTOR	79		NEMA-NOM-EFFICIENCY	93		
						MAX CORR KVAR	20		GUARANTEED EFFICIENCY	91.7
						NEMA NOM/CSA QUOTED EFF				
						MOTOR WEIGHT				

Parts List		
Part Number	Description	Quantity
SA296094	SA A40-6568-0790	1.000 EA
RA282145	RA A40-6568-0790	1.000 EA
421948032	LABEL, MYLAR	1.000 EA
NP2496L	MOTOR LUBE NAMEPLATE	1.000 EA
000613006PU	N/P (RELEASE QTY 10,000) UL CSA LABEL	1.000 EA
000692000FF	N/P	1.000 EA
000692000VD	LABEL WARNING	1.000 EA
NP2349L	SUPER-E ,SS, CSA, CSA SUPER-E	1.000 EA
089412501A	BRKT FTMT G400 FIN MACH 6316 89412500WCA	1.000 EA
083198127A	G400 MOLDED FAN COVER	1.000 EA
034180012DA	KEY 1X4X1/4X1-1/2 L	1.000 EA
702618004T	FAN KB 182/70 (112) 440	1.000 EA
004824015A	GREASE POLYREX EM	0.880 LB
032018020EK	HHCS 5/8-11X2-1/2 PLTD.	4.000 EA
032018010CK	HHCS 3/8-16X1-1/4 PLTD. 032018010CR	4.000 EA
032018024CK	HHCS 3/8-16X3 PLTD.	3.000 EA
415096002A	CPLG 1/8 HEX TYPE	1.000 EA
410700000DA	WAVY SPRING WASHER	1.000 EA
034000014AB	WSH ID.406 OD.812 TH.065	4.000 EA
034530056BB	P/NIP 1/4X7 SCHED 40	1.000 EA
034530052AB	P/NIP 1/8X6-1/2 GALV.	1.000 EA
034690005AB	PPLG 3/4 PLATED	1.000 EA
034690001AB	1/8" NPT SQHDPLG	1.000 EA
034690001AB	1/8" NPT SQHDPLG	1.000 EA

Parts List (continued)		
Part Number	Description	Quantity
034631002AB	BUSH 1/4 TO 1/8 PLTD.	1.000 EA
034690002AB	PPLG 1/4" PLTD.	1.000 EA
034690001AB	1/8" NPT SQHDPLG	1.000 EA
089412501A	BRKT FTMT G400 FIN MACH 6316 89412500WCA	1.000 EA
032018020EK	HHCS 5/8-11X2-1/2 PLTD.	4.000 EA
032018024CK	HHCS 3/8-16X3 PLTD.	3.000 EA
077176000L	C/BOX, 360-400	1.000 EA
077176001A	CBOXC, PAINTED 360-400	1.000 EA
043292000AJ	GASK 320-400	1.000 EA
402731001A	GASK 360-440	1.000 EA
418150003A	GREASE FITTING CAP	1.000 EA
MG1025Y17	WILKOFAS, 789.701, SUPER E PEARL GOLD	0.375 GA
032018005AK	HHCS 1/4-20X5/8 PLATED	4.000 EA
032018008CK	HHCS 3/8-16X1L PLATED	4.000 EA
035000001A	ALFTG 1/8" 1610-BL	1.000 EA
415000103D	T/LUG #4AWG-1/0AWG W/HOLE FOR .250 BOLT	1.000 EA
406099000A	PLUG - FAN COVER 320-440	1.000 EA
033512004LB	HHTTS 1/4-20X1/2 PLTD.	1.000 EA
035000001A	ALFTG 1/8" 1610-BL	1.000 EA
418150003A	GREASE FITTING CAP	1.000 EA
033775004EA	DRSCR #6-1/4 304 S.S.	2.000 EA
034180044JA	KEY 3/4X3/4X5-1/2 L	1.000 EA
604797045	STD. 400 FRAME SKID	1.000 EA
032510024D	CARRIAGE BOLT - 444	2.000 EA

Product Information Packet: EM4468T - 60HP,890RPM,3PH,60HZ,405T,TEFC,F1

034001014AB	FLAT WASHER 3/8"PLATED	2.000 EA
034001016AB	WSHR .562ID 1.375OD .109	2.000 EA
033300014AC	HEX NUT, SHIPPING - 400	2.000 EA
604799003C	PLASTIC BAG 42X32X46	1.000 EA

REL. S.O.	FRAME	HP	TYPE	PHASE/HERTZ	RPM	VOLTS
	405T	60	P	3/60	890	230/460
AMPS	DUTY	AMB °C/ INSUL.	S.F.	NEMA DESIGN	CODE LETTER	ENCL.
152/76	CONT	40/F	1.15	B	F	FOXE
E/S	ROTOR	TEST S.O.	TEST DATE	STATOR RES. @25 °C (OHMS (BETWEEN LINES))		
496302	418142071BR	---	---	.0285/.114		

PERFORMANCE

LOAD	HP	AMPERES	RPM	POWER FACTOR %	EFFICIENCY %
NO LOAD	0	37.2	900	3.70	0
1/4	15.0	40.7	897	38.4	90.2
2/4	30.0	49.5	894	60.9	93.3
3/4	45.0	61.6	891	73.0	93.7
4/4	60.0	76.0	888	79.3	93.3
5/4	75.0	92.3	884	82.3	92.4

SPEED TORQUE

	RPM	TORQUE % FULL LOAD	TORQUE LB.-FT.	AMPERES
LOCKED ROTOR	0	148	525	405
PULL UP	280	127	451	380
BREAKDOWN	844	225	800	235
FULL LOAD	888	100	355	76.0

AMPERES SHOWN FOR 460. VOLT CONNECTION. IF OTHER VOLTAGE CONNECTIONS ARE AVAILABLE, THE AMPERES WILL VARY INVERSELY WITH THE RATED VOLTAGE

REMARKS: XE MOTOR-TYPICAL DATA-NEMA NOM. EFF. 93.0 PCT.
GUARANTEED MIN. EFF. 92.4 PCT.

BALDOR	DR. BY P. B. GREENE	A-C MOTOR
	CK. BY K. W. KANOUFF	
	APP. BY K. W. KANOUFF	PERFORMANCE DATA
	DATE 10/16/90	ISSUE DATE 10/16/90

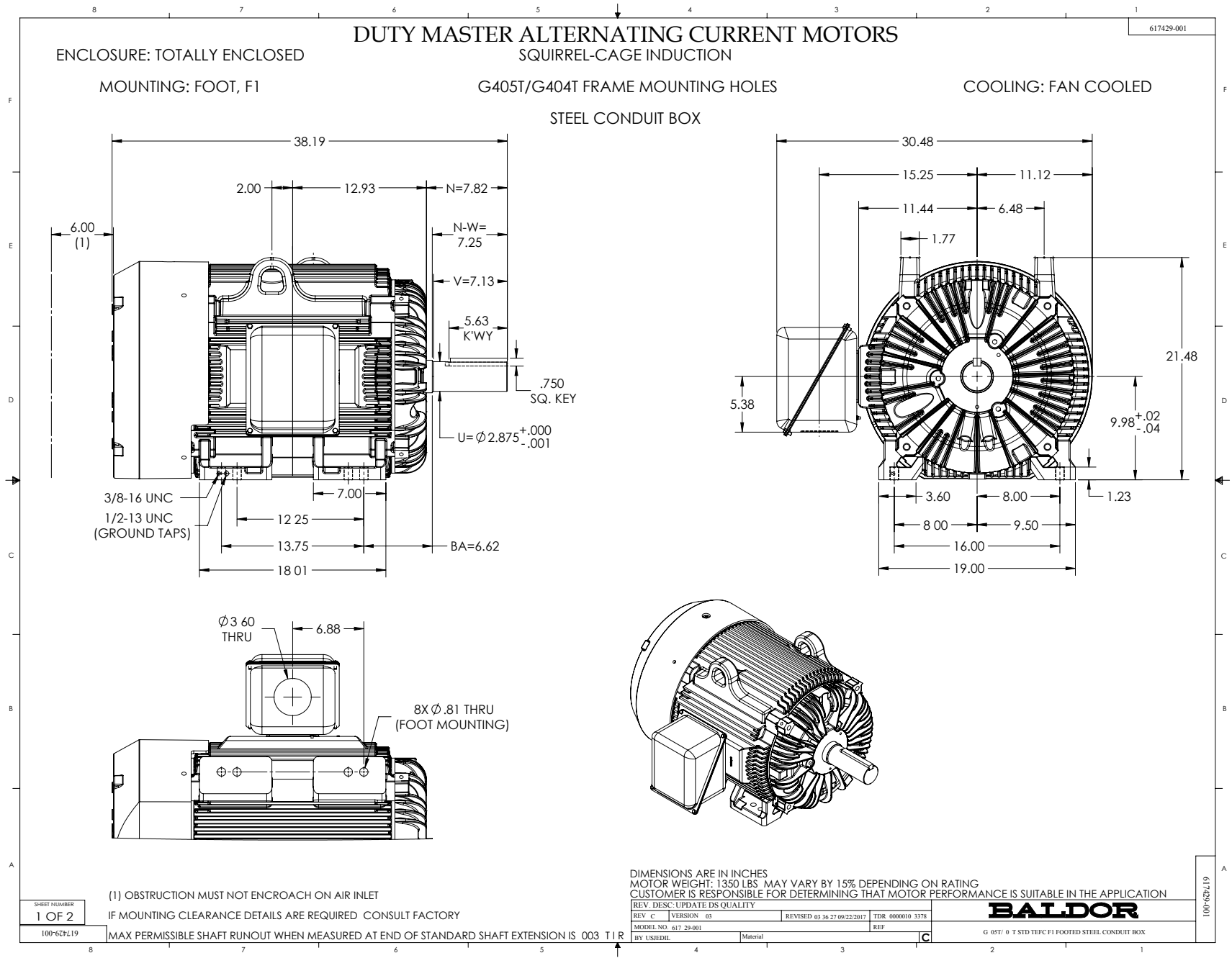

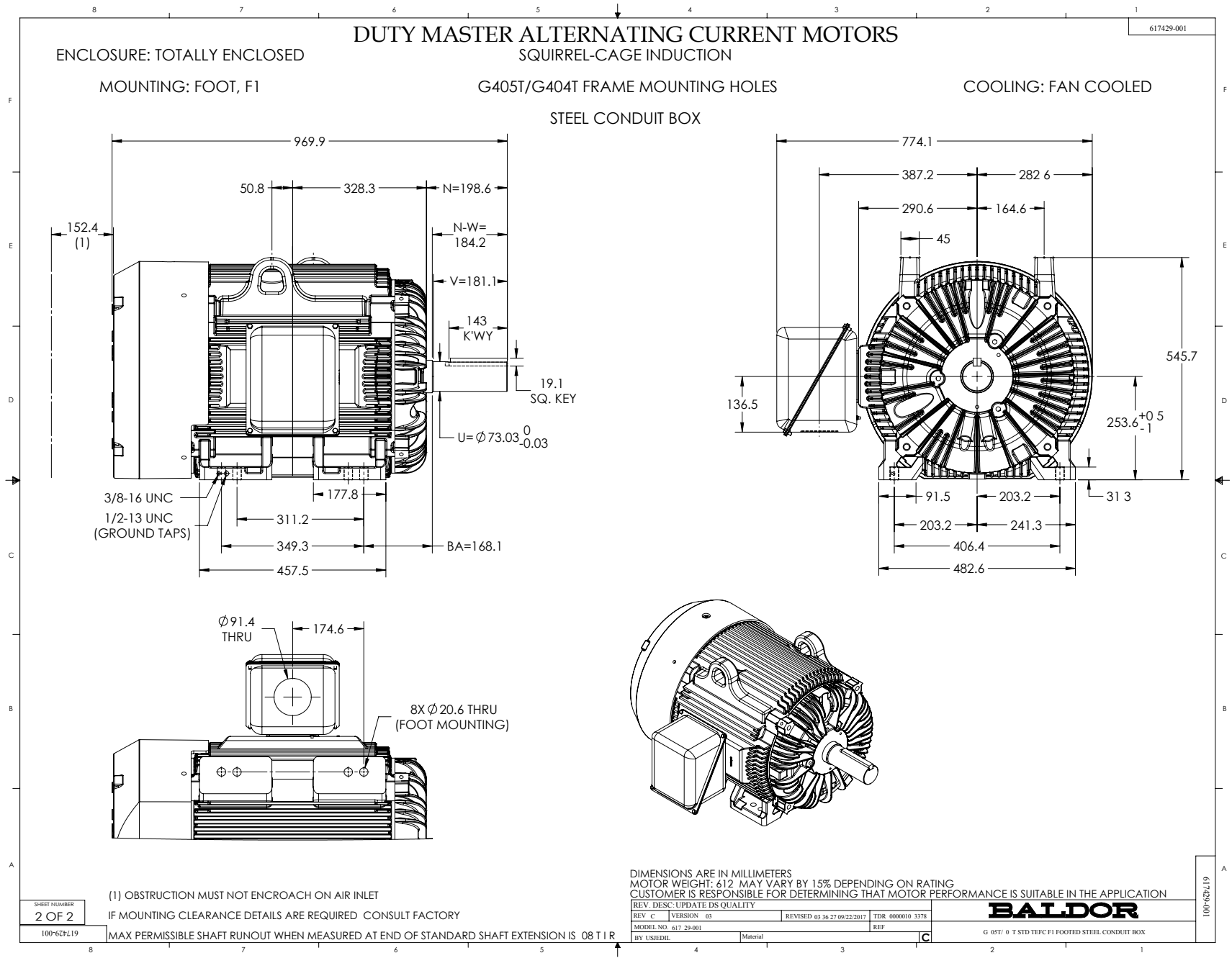

Marketing maintained PDF of MN408:

[MN408?ManNumber=MN408](#)

Marketing maintained PDF of MN416:

[MN416?ManNumber=MN416](#)